

Specyfikacja / Specifications

Model:	FORIO RO-ES111	FORIO SQ-ES111
Ref.no.	HB12074/HB12075	HB12078/HB12079
Shape	Round	Square
Power	max. 50W	max. 50W
Input voltage	180-240VAC / 50-60Hz	180-240VAC / 50-60Hz
Bulb	GU10, ES111	GU10, ES111
Dimensions(L*W*H)	Ø160*145mm	160*145mm

Przed instalacją zawsze wyłącz zasilanie główne

Always turn off main power before installation

Před instalací vždy odpojte přístup napájení

Üzembehelyezés el"ott mindig kapcsolja ki az áramot

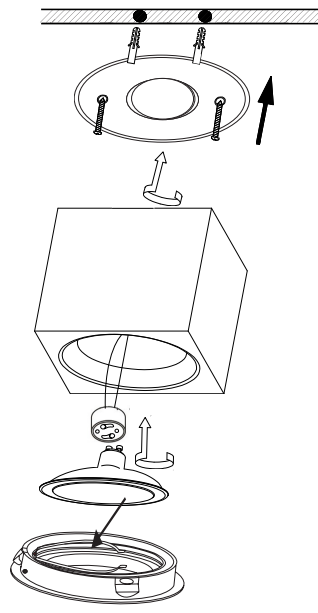
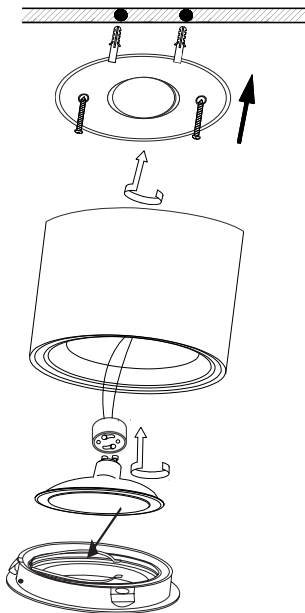
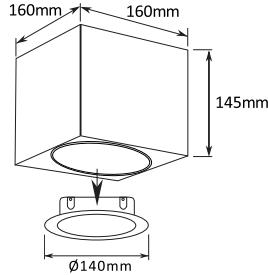
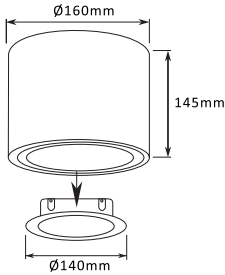

Instalacja oprawy powinna być wykonana przez wykwalifikowanego elektryka

Installation should be carried out by your local electrician

Instalace musí být provedena osobou s certifikací v oboru elektro (pracovník dle vyhl. 50/78 Sb. S. § 6,7 a vyšší)

A lámpatest üzembehelyezését képesített villanyszerelő végezze

Holdbox

96-321 Żabia Wola

Katowicka 11, Bieniewiec

www.holdbox.eu

IP20  

  **RoHS**

